

Features

- 2-channel signal conditioner
- 24 V DC supply (loop powered)
- Current input/output 4 mA ... 20 mA
- transmitter power supply
- Accuracy 0.1 %
- Reverse polarity protection
- Up to SIL 2 acc. to IEC 61508

Function

This signal conditioner provides the galvanic isolation between field circuits and control circuits.

The device can be used as a repeater or transmitter power supply for 2-wire transmitters.

This device is loop powered. No additional power supply has to be connected.

Use the technical data to verify that proper voltage is available to the field devices.

Assembly

Front view

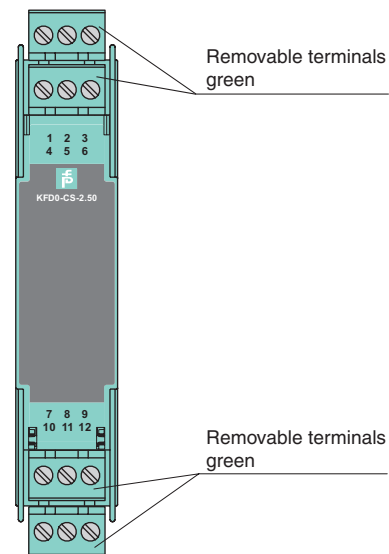

CE

SIL 2

Connection

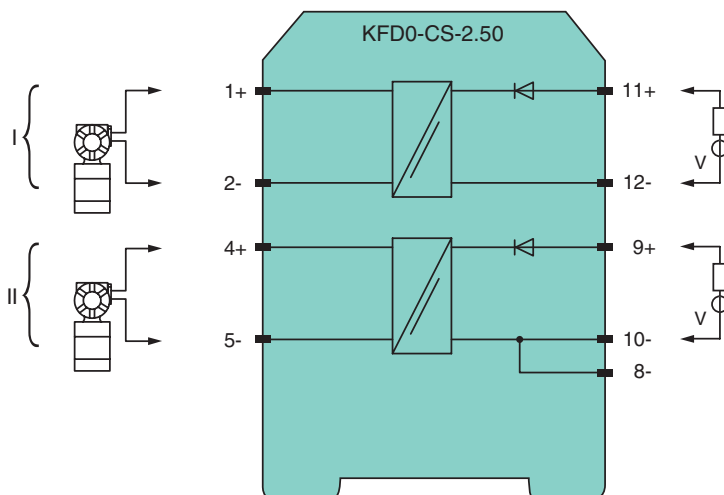

Release date 2017-08-09 14:20 Date of issue 2017-08-09 126992_eng.xml

General specifications	
Signal type	Analog input/analog output
Functional safety related parameters	
Safety Integrity Level (SIL)	SIL 2
Supply	
Rated voltage U_r	loop powered
Power dissipation	0.4 W
Control circuit	
Connection	terminals 12-, 11+; 8-, 10-, 9+
Voltage	10 ... 35 V DC
Current	4 ... 20 mA
Power dissipation	< 150 mW per channel at 25 mA and $U < 26.1$ V < 400 mW per channel at 25 mA und $U > 26.1$ V
Field circuit	
Connection	terminals 1+, 2-; 4+, 5-
Voltage	$\geq 0.9 \times U_{in} - (0.23 \times \text{current in mA}) - 0.7$ for $10 \text{ V} < U_{in} < 26.1 \text{ V}$ $\geq 23 \text{ V} - (0.23 \times \text{current in mA})$ for $U_{in} > 26.1 \text{ V}$
Short-circuit current	max. 100 mA
Transfer current	max. 25 mA
Transfer characteristics	
Accuracy	0.1 %
Deviation	
After calibration	$U_{in} \geq 5 \text{ V} \pm 20 \mu\text{A}/U_{in} \leq 5 \text{ V} \pm 50 \mu\text{A}$ incl. calibration, linearity, hysteresis and output load fluctuations at the field side; at 20 °C (68 °F)
Influence of ambient temperature	$\leq \pm 2 \mu\text{A/K}$ at $U_{in} \leq 20 \text{ V}$; $\leq \pm 5 \mu\text{A/K}$ at $U_{in} > 20 \text{ V}$
Rise time	$\leq 5 \text{ ms}$ at 4 ... 20 mA and $U_{in} = \text{input voltage} < 26 \text{ V}$
Galvanic isolation	
Input/Output	basic insulation according to IEC 62103, rated insulation voltage 300 V _{eff}
Indicators/settings	
Labeling	space for labeling at the front
Directive conformity	
Electromagnetic compatibility	
Directive 2014/30/EU	EN 61326-1:2013 (industrial locations)
Conformity	
Insulation coordination	EN 50178:1997
Electromagnetic compatibility	NE 21:2006
Degree of protection	IEC 60529:2001
Ambient conditions	
Ambient temperature	-20 ... 60 °C (-4 ... 140 °F)
Mechanical specifications	
Degree of protection	IP20
Connection	screw terminals
Mass	approx. 100 g
Dimensions	20 x 107 x 115 mm (0.8 x 4.2 x 4.5 inch) , housing type B1
Mounting	on 35 mm DIN mounting rail acc. to EN 60715:2001
General information	
Supplementary information	Observe the certificates, declarations of conformity, instruction manuals, and manuals where applicable. For information see

Release date 2017-08-09 14:20 Date of issue 2017-08-09 126992_eng.xml